



www.havayesh.com



DUCT SPLIT AIR CONDITIONER

Saran

Life's Pleasant Breeze



AIR CONDITIONING MFG.GROUP

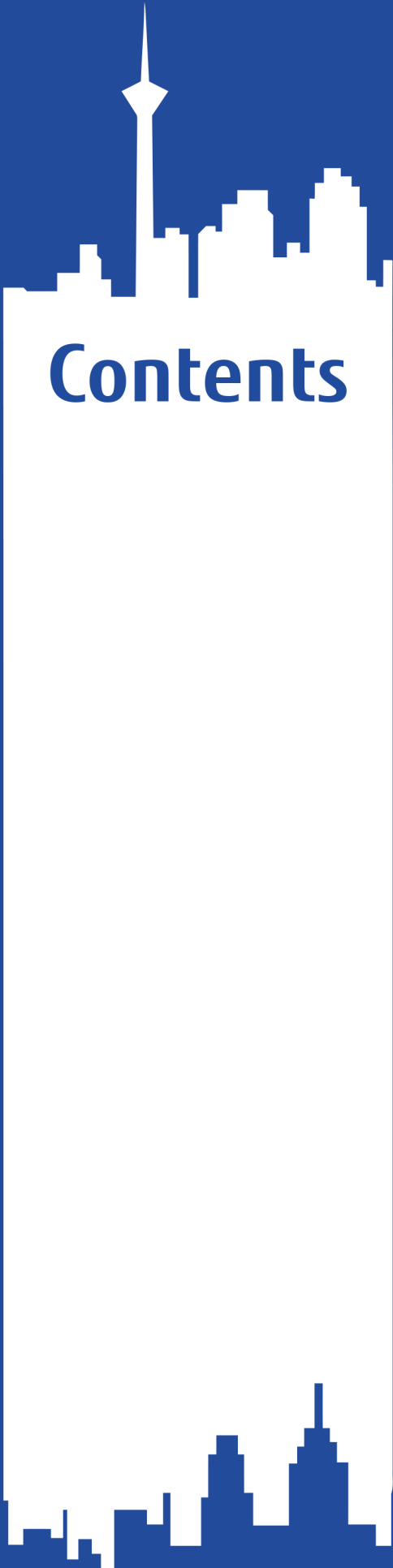

Contents

Nomenclature	4
Introduction	5
Technical Features	5
Technical Specifications	6
Actual Cooling and Heating Capacities	7
Installation Instruction	8
Dimensions	11



NOMENCLATURE

SR **DS** - **24** **H**

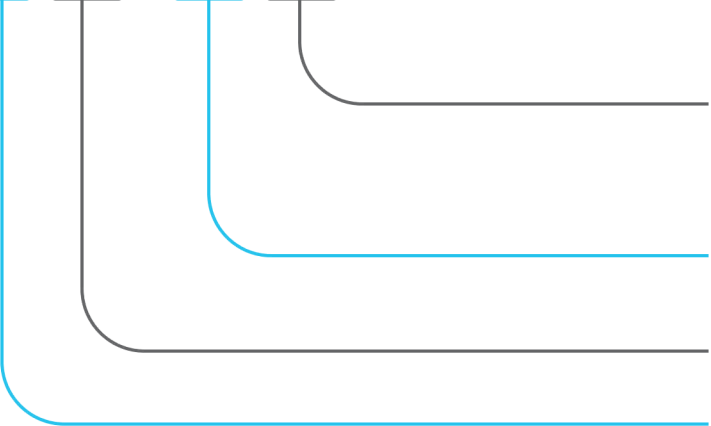

Type:
C: Cooling Only
H: With Hot Water Coil

Nominal Cooling Capacity (kBtu/hr)

Duct Split

Saran



Introduction

Saran ducted split air conditioners are the optimum air conditioning solutions for places which require ceiling installation above false ceiling and also require optimum air distribution, increased air throw distance and minimum sound levels.

Technical Features

- Compact invisible indoor unit with low slim profile and height for easy installation above false ceiling.
- Superior air distribution performance, three speeds fan with external static pressure up to 125 Pa to satisfy air flow and static pressure requirements to suit various applications.
- High efficiency indoor unit design: Indoor unit equipped by high efficiency coil with wavy corrugated fins and high efficiency, low power consumption electromotor.
- Supper quiet operation indoor unit design: Indoor unit equipped by high efficiency forward curved fans.
- Optional hot water coil in indoor unit for heating purposes.
- Compact outdoor design with minimum footprint.
- High efficiency outdoor unit design: outdoor unit equipped by high efficiency coils with inner groove tubes; mechanically bonded to hi-efficiency aluminum fins to match for a maximum efficiency and high efficiency hermetically sealed scroll type compressor.
- Quiet operation outdoor unit design: Condenser fan is propeller type with aluminum alloy blades and directly driven for quiet operation.
- Easy service and maintenance: Designed to make servicing easier for the contractor, access panels are provided for all controls and the compressor from the side of the unit.
- Factory installed service valve with sweat connections to provide quick and accurate installation for startup and servicing.
- Easy wiring / electrical and piping connections.
- Factory Test and charging: Each unit is pressure tested, vacuum tested, evacuated and charged with refrigerant requested then it tested at the factory's test bench under the design conditions specified by the customer. Before shipment, each unit is recheck for pressure and refrigerant charge control.

Table 1: Technical Specifications

Models			SRDS-24	SRDS-30	SRDS-36	SRDS-42	SRDS-48	SRDS-60	
SPECIFICATION	Power Supply		230/1/50				380/3/50		
	Cooling	Capacity	Btu/hr	21000	27400	33000	38600	46800	57000
		Power Input	kW	1.73	2.08	2.73	3.13	3.69	4.57
		Rated Current	A	7.95	9.7	12.95	15.35	7.64	9.0
	Heating	Capacity	Btu/hr	31100	37000	44100	49300	55300	68500
	Refrigerant	Type		R22					
		Charge	gr	1800	2200	3000	3600	4000	4700
	Maximum Pipe Length		m	20	20	20	20	25	25
	Maximum Height Difference		m	10	10	10	10	10	10
	Piping Connections	Liquid Line	in	3/8"	3/8"	3/8"	3/8"	5/8"	5/8"
Suction Line		in	5/8"	5/8"	3/4"	3/4"	7/8"	7/8"	
INDOOR UNIT	Nominal Air Flow Rate		CFM	650	850	1000	1200	1400	1700
	Blower	Type		Centrifugal Forward-Curved					
		Qty		2					
	Electrical Data	Max. Power Consumption	kW	0.21	0.21	0.30	0.30	0.43	0.85
		Max. Current	A	1	1	1.4	1.4	2	4
		Power Supply		230/1/50					
	Dimensions (WxHxD)		mm	1000x310x770	1000x310x770	1080x350x850	1080x350x850	1080x350x850	1080x430x1000
	Weight		kg	66	70	80	86	90	115
	Compressor Type			Scroll					
	Condenser Air Flow Rate		CFM	2000	2800	4000	3500	3500	5000
Fan	Type		Direct Drive Axial-flow Propeller						
	Qty		1				2		
Electrical Data	Max. Power Consumption	kW	2.075	2.53	3.28	3.78	4.44	5.57	
	Max. Current	A	9.5	11.8	15.4	17.95	8.54	10.25	
	Power Supply		230/1/50				380/3/50		
Dimensions (WxHxD)		mm	1030x685x400	1030x685x400	1130x835x400	1130x835x400	1130x1235x400	1130x1235x400	
Weight		kg	125	130	145	175	245	255	
OUTDOOR UNIT	Compressor Type			Scroll					
	Condenser Air Flow Rate		CFM	2000	2800	4000	3500	3500	5000
	Fan	Type		Direct Drive Axial-flow Propeller					
		Qty		1				2	
	Electrical Data	Max. Power Consumption	kW	2.075	2.53	3.28	3.78	4.44	5.57
		Max. Current	A	9.5	11.8	15.4	17.95	8.54	10.25
		Power Supply		230/1/50				380/3/50	
	Dimensions (WxHxD)		mm	1030x685x400	1030x685x400	1130x835x400	1130x835x400	1130x1235x400	1130x1235x400
Weight		kg	125	130	145	175	245	255	

NOTE

- Cooling capacities are based on 85°F DB/ 71°F WB indoor air temperature and ambient temperature 95°F DB/75°F WB.
- Heating coil is available as an option and heating capacities are based on 170°F/150°F entering/leaving hot water temperature and 68°FDB indoor air temperature.
- Maximum ambient temperature for units running is 115 °F.
- The above specifications are subject to change without prior notice.

Actual Cooling and Heating Capacities

Cooling and heating capacity of Saran ducted split air conditioners presented in the “technical specification” table, indicate capacity of them at standard condition; so for other condition, following performance adjustment factors shall be attended in unit selection base on following formula:

Total Cooling Capacity= Nominal Cooling Capacity(Table1)×C1(Table2)×C2(Table3)×C5(Table6)

Sensible Cooling Capacity= Nominal Cooling Capacity(Table1)×C1(Table2)×C2(Table3)×C3(Table4)×C5 (Table6)

Total Heating Capacity= Nominal Heating Capacity(Table1)×C4(Table5)×C5(Table6)

Table 2: Entering Air Wet Bulb Temperature Correction Factor(C1)

Entering Air Wet Bulb Temperature (°F)	SRDS-24	SRDS-30	SRDS-36	SRDS-42	SRDS-48	SRDS-60
59	0.836	0.839	0.830	0.837	0.838	0.840
63	0.890	0.891	0.885	0.889	0.889	0.893
67	0.945	0.945	0.939	0.943	0.942	0.946
71	1.000	1.000	1.000	1.000	1.000	1.000

Table 3: Ambient Temperature Cooling Capacities Correction Factor(C2)

Ambient Temperature (°F)	SRDS-24	SRDS-30	SRDS-36	SRDS-42	SRDS-48	SRDS-60
95	1.000	1.000	1.000	1.000	1.000	1.000
100	0.971	0.974	0.970	0.972	0.970	0.970
105	0.943	0.945	0.939	0.940	0.940	0.940
110	0.912	0.912	0.909	0.909	0.910	0.911
115	0.881	0.880	0.876	0.878	0.878	0.882

Table 4: Approximate Sensible Cooling Capacity Factor (C3)

Entering Air Wet Bulb Temperature (°F)	Entering Air Dry Bulb Temperature (°F)			
	75	80	85	90
59	0.94	0.97	1.00	1.00
63	0.74	0.80	0.92	1.00
67	0.56	0.70	0.84	1.00
71	0.41	0.52	0.64	0.74

Table 5: Entering Hot Water Temperature Correction Factor (C4)

Entering Hot Water Temp. (°F)	160	180	200	220
Heating Capacity Correction Factor	0.75	1.00	1.25	1.50

Table 6: Altitude Correction Factor (C5)

Altitude (ft)	0	2000	4000	6000
Correction Factor	1.00	0.99	0.98	0.96

Installation Instruction

1) Following points should be considered for installation location of the indoor unit:

- Keep away from direct sunlight.
- Make sure the suspension bracket is strong enough to withstand the unit's weight.
- Select a place for easily connection of the drain hose.
- The air inlet and outlet ports should not be obstructed so that the indoor air circulates well.
- Make sure the convenient connect of the connection pipes.
- Select a location that is far away from the combustible or explosive material and gas.
- Select a location that is far away from the cankerous material, frog, dusk or moist.
- For easy drainage of the condensation water, the drain hose should be installed with a downward gradient. To avoid the condensation, the connection pipe joint should be insulated with thermal insulation material.
- To avoid condensation of dew and water leakage, gas pipe and liquid pipe of refrigerant should be insulated with thermal insulation material and adhesive tape
- The indoor unit should be installed horizontally. To install an indoor unit needs 4 hanging rods, and each hanging rod should at least withstand four times of the unit's weight.
- Consider following service area for unit installation:

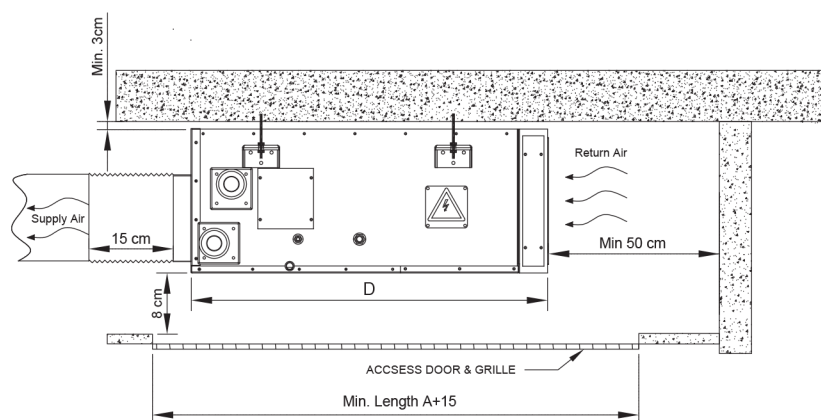
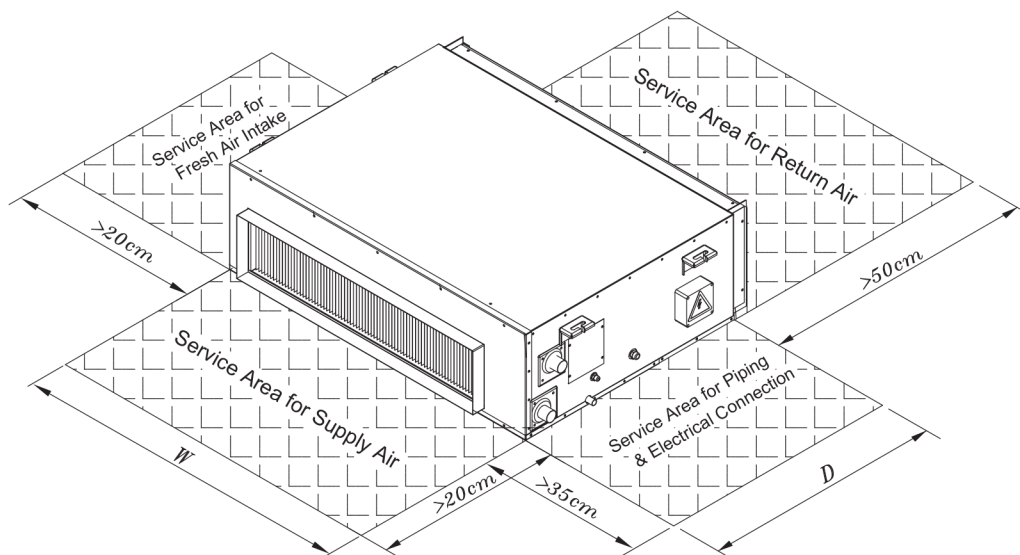

NOTE

- W= Indoor unit width
- D= Indoor unit depth

2) Following points should be considered for installation location of the outdoor unit:

- Outdoor unit should be installed in a steady and stable place.
- To reduce the length of the refrigerant pipe and bend number, make sure the indoor unit and outdoor unit be close to each other.
- Ensure the operation noise do not disturb neighbors and passerby.
- Do not install the unit where it will be exposed to direct sunlight or other radiation heat source.
- The inlet and outlet port should not be blocked.
- Make sure the well air circulation.
- Select a location that is far away from combustible or explosive material, dust, and fog or moist.
- To avoid condensation of dew and water leakage, gas pipe and liquid pipe of refrigerant should be insulated with thermal insulation material and adhesive tape.
- Consider following service area for unit installation:

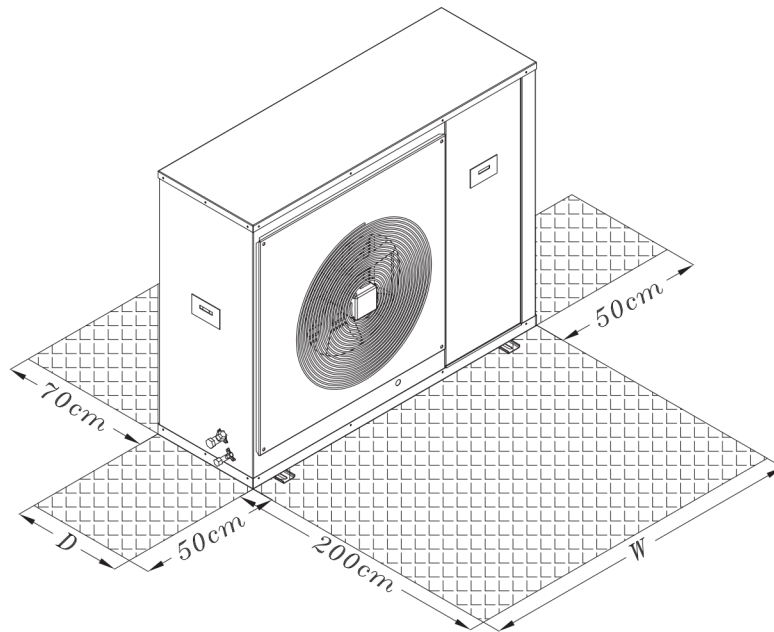

NOTE

- W= Outdoor unit width
- D= Outdoor unit depth

Refrigerant Pipe Connection

The pipes' connection should be confirm base on following principles:

- Make sure to lessen the length of connecting pipe, the height difference between the indoor and outdoor unit, and the number of bends, and enlarge the diameter of bends, maximum pipe length and height differences denoted in following table:

Model	SRDS-24	SRDS-30	SRDS-36	SRDS-42	SRDS-48	SRDS-60
Maximum Pipe Length (m)	20	20	20	20	25	25
Maximum Height Difference (m)	10	10	10	10	10	10

- The pipes should not be shriveled when the pipes are connecting. The bend diameter should be longer than 200 millimeter. The connecting pipes should not be extended or curved frequently and the curving process should not be larger than 3 times in the same bending position.

- The refrigerant in the conditioner unit is enough for the connecting pipes of 5 meters, if the pipe is longer than 5 meters; additional supplement refrigerant should be supplied. When the height difference between the indoor unit and outdoor unit is larger than 4 meters, an oil trap should be employed for every 4 meters.
- If the indoor unit were situated below the outdoor unit, the suction riser must be trapped so as to prevent liquid refrigerant from collecting at the outlet of the indoor unit while the system is idle.

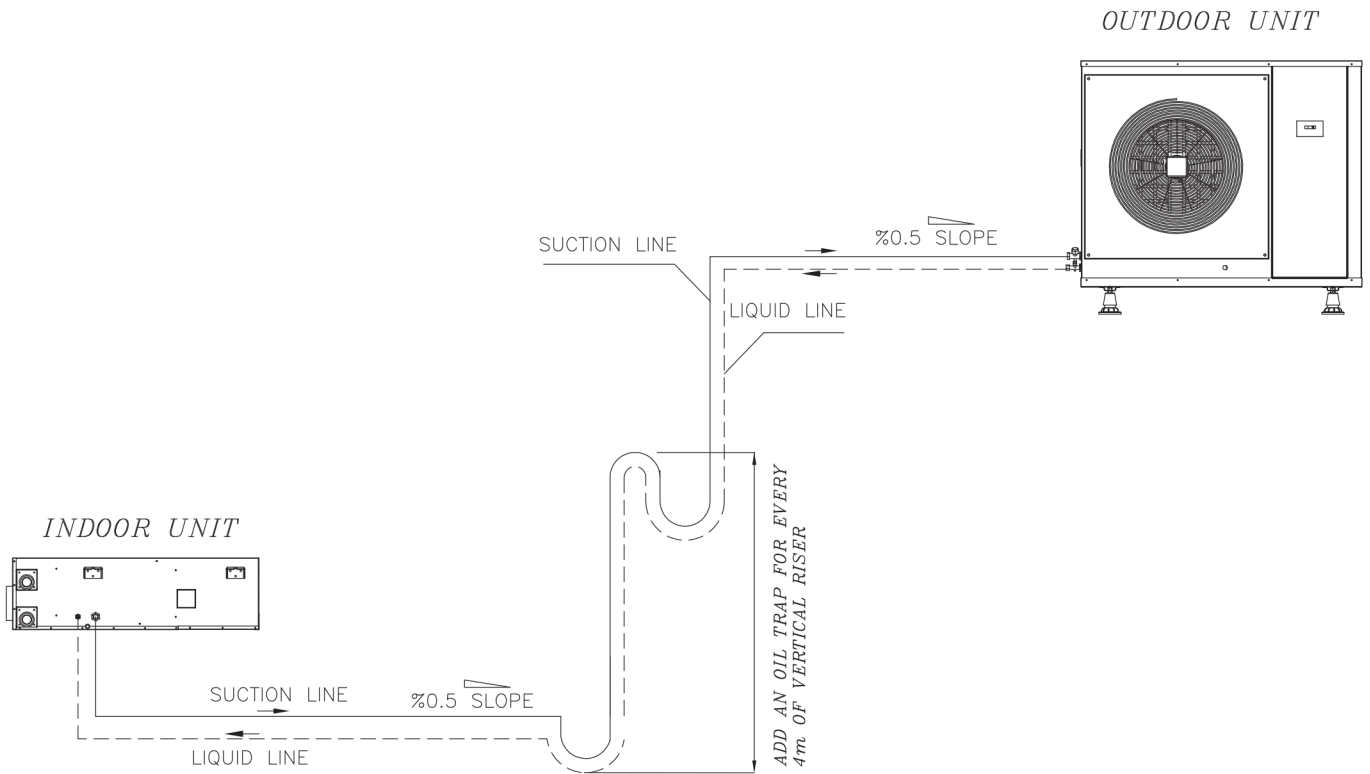

- If the indoor unit lies above the outdoor unit, the suction line must have a loop at the indoor unit's outlet to prevent refrigerant from draining into the compressor during off-cycles.

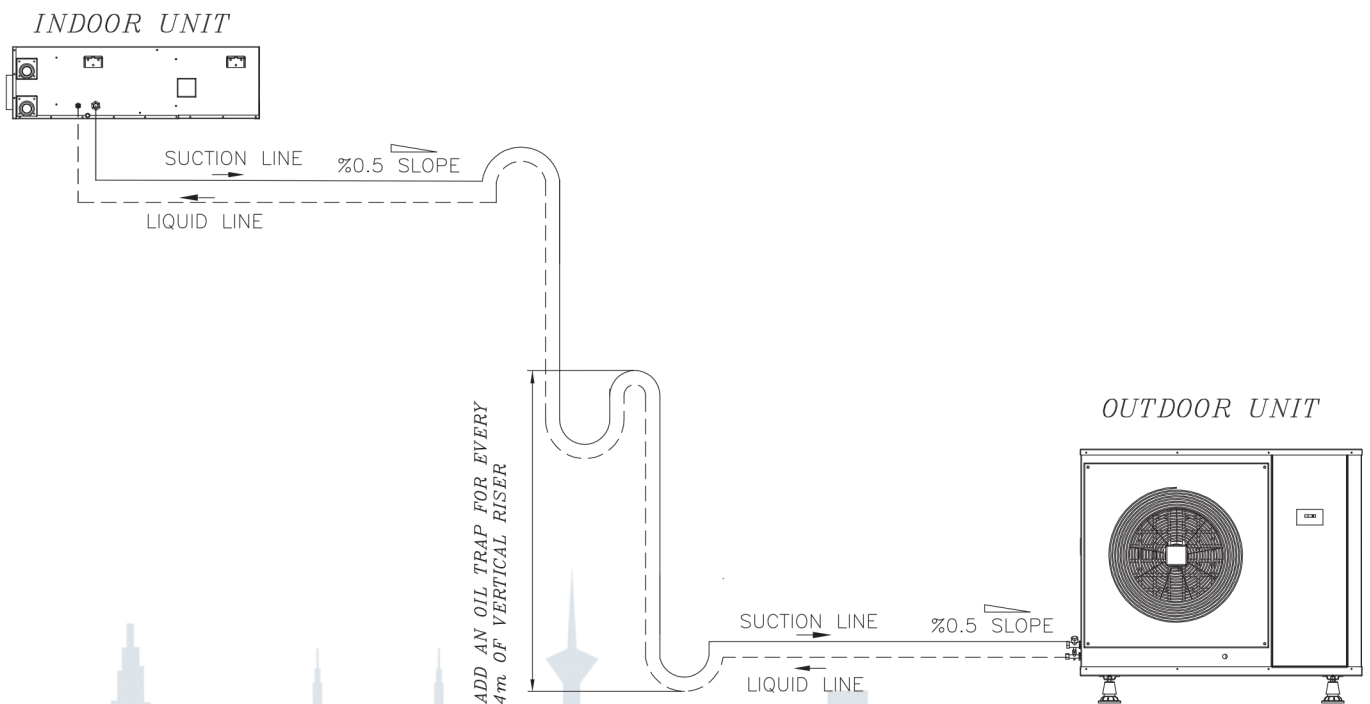

Electrical Wiring

- All of the supplied components, material, and electrical operation should be accorded with the local principles.
- The power supply should adopt the rated voltage and special circuit for the ducted air conditioning unit.
- All circuit connections should be carried by the qualified electrician.
- The units should be well earthing to the ground by professionals.
- Install a central switch which can cut all the power switches.
- Please accord to electrical diagram on the unit when connecting the wires.
- Please choose the specification of the power cables according to the power capacity and the installation conditions of the unit. Fix the wires with wire clamp and assemble the electric cover after confirmation.

Dimensions

INDOOR UNIT

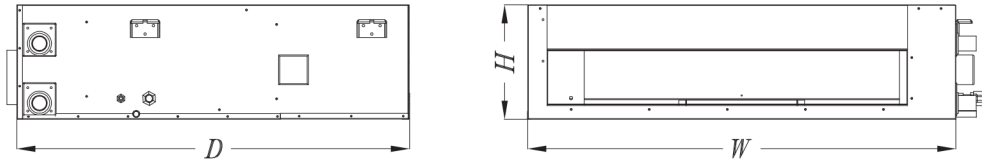

Model	SRDS-24	SRDS-30	SRDS-36	SRDS-42	SRDS-48	SRDS-60
W	1000	1000	1080	1080	1080	1080
H	310	310	350	350	350	430
D	770	770	850	850	850	1000

NOTE

- All dimensions are in mm.

OUTDOOR UNIT

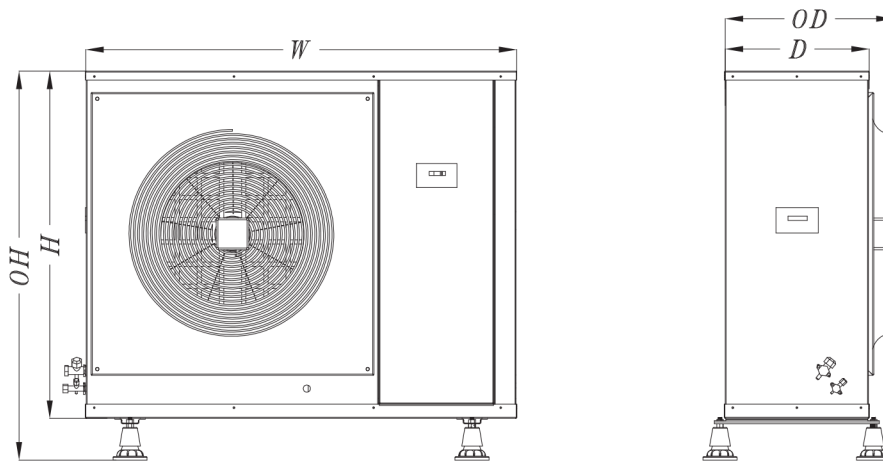

Model	SRDS-24	SRDS-30	SRDS-36	SRDS-42	SRDS-48	SRDS-60
W	1030	1030	1130	1130	1130	1130
H	685	685	835	835	1235	1235
OH	785	785	935	935	1335	1335
D	400	400	400	400	400	400
OD	540	540	540	540	540	540

NOTE

- All dimensions are in mm.

