



azarnasim  
AIR CONDITIONING COMPANY

# MINI CHILLER





## **Introduction**

---

Azar Nasim company designs and manufactures integrated air cooled mini chillers equipped with high efficiency scroll compressors for cooling requirement of apartments, office buildings, luxury villas and etc.

These mini chillers are designed and manufactured as complete package in cooling capacities from 3.5 to 10 TOR in single and three phase type.

Prominent feature of this product is its compact dimensions which is suitable for installation in small areas.

## **Body**

---

The body is made of Aluminum profile, stainless steel or Carbon- steel and galvanized sheet with appropriate thickness and electro-static paint coating, according to the technical specifications.

## **Scroll Compressor**

---

The company utilizes compressors from reputable brands such as Danfoss, Copeland and Hanbell for the units to have quiet and reliable performance over a wide operating temperature range. However, in order to protect the compressors from damage, a phase protector (for model which is available) is provided to prevent the compressors from rotating in the wrong directions.

## **Evaporator**

---

Both of two types of evaporators (Shell & Tube and Plate heat exchanger) with high efficiency and compact design are available, according to customers request.



## Chilled Water Circuit

---

AN MCH series has been designed fully integrated and equipped with key hydronic components such as brazed plate or shell & tube heat exchanger, expansion tank and water circulating pump. As all hydronic components are assembled and tested in the factory, installation of additional component on site can be eliminated.

## Features

---

- High efficiency
- Low noise (Azar Nasim uses low noise fans and components to achieve its low noise level)
- Compact structure Its compact design and excellent performance make it suitable for a wide range of applications.
- Safety running
- Easy maintenance
- Affordable price
- Long life
- High ambient function up to 125 °F

## Nomenclature

---

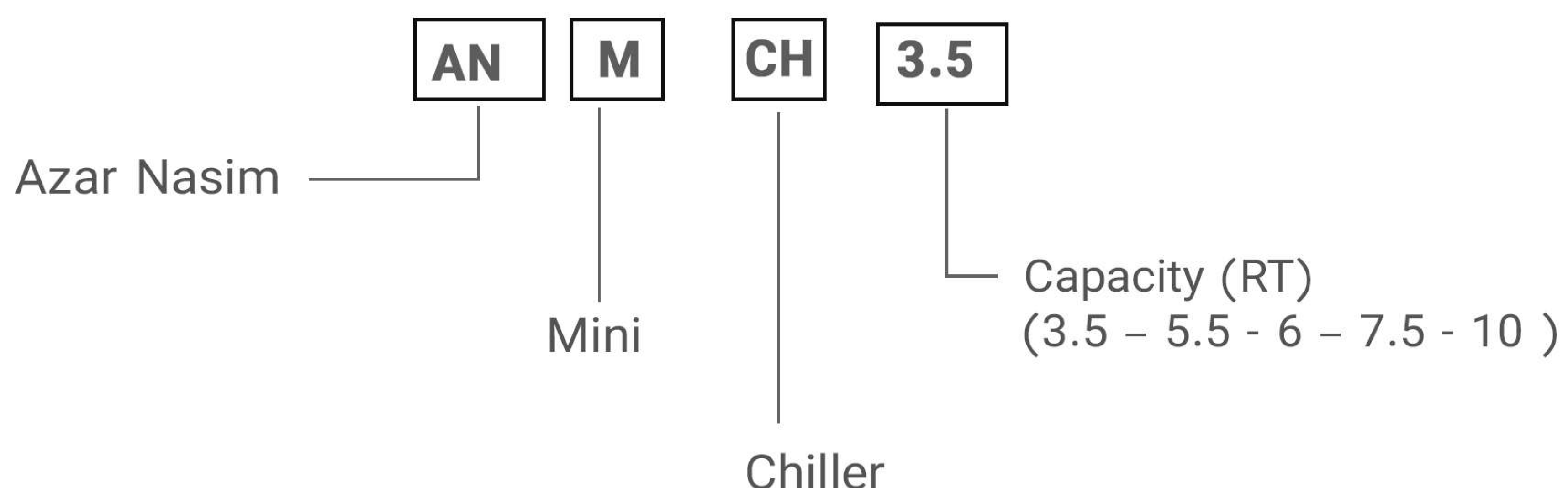



## Technical Data

Model			AN MCH-3.5	AN MCH-5	AN MCH-6	AN MCH-7.5	AN MCH-10	
Nominal Capacity		RT	3.5	5	6	7.5	10	
Electrical Data	Total Power Consumption	kW	4.37	5.46	5.87	7	10.6	
	Total Current	A	9.11	11.27	12.1	14.93	20.12	
	Total Power Supply	V/Ph/Hz	220/1~/50	380/3~/50				
Protective Devices			High/low pressure switch, compressor thermal protection, over current protection, lose of phase/anti-phase protection, antifreez protection, water flow switch					
Refrigerant		Type	R22					
Compressor	Type		Scroll					
	No.		1					
	COP		3.67	3.76	3.96	3.96	3.99	
Evaporator	Type		Plate Or Shell & Tube					
	Water Flow Rate	GPM	7	10.2	16.5	16.5	22	
	Water Inlet/Outlet	Plate	Inch	1	1	2	2	2
		Shell & tube	Inch	1 1/4	1 1/4	1 1/4	1 1/2	1 1/2
Condenser	Heat Exchanger		Aluminum fin-copper tube					
	Fan	quantity	1	1	2	2	2	
Pump	Water Flow Rate	GPM	8	12	17	18	22	
	Head	Ft	10	12.5	14	15	20	
Weight	Plate	kg	150	170	190	220	265	
	Shell & Tube	kg	200	225	240	270	320	
<b>Note:</b> • Cooling capacities are based on conditions of 104°F ambient, 44°F leaving chilled water temperature and 54°F entering chilled water .								

Table 1



# Dimensions

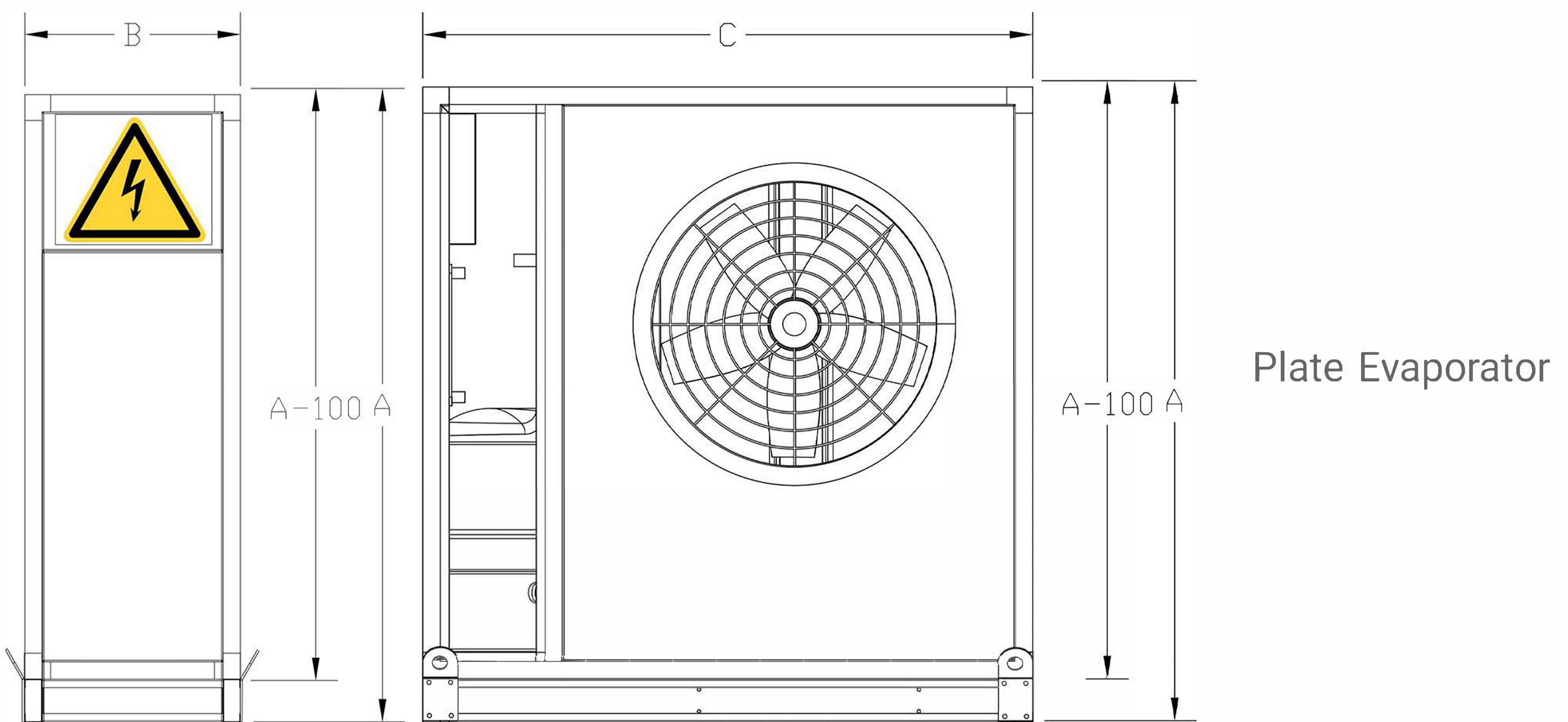
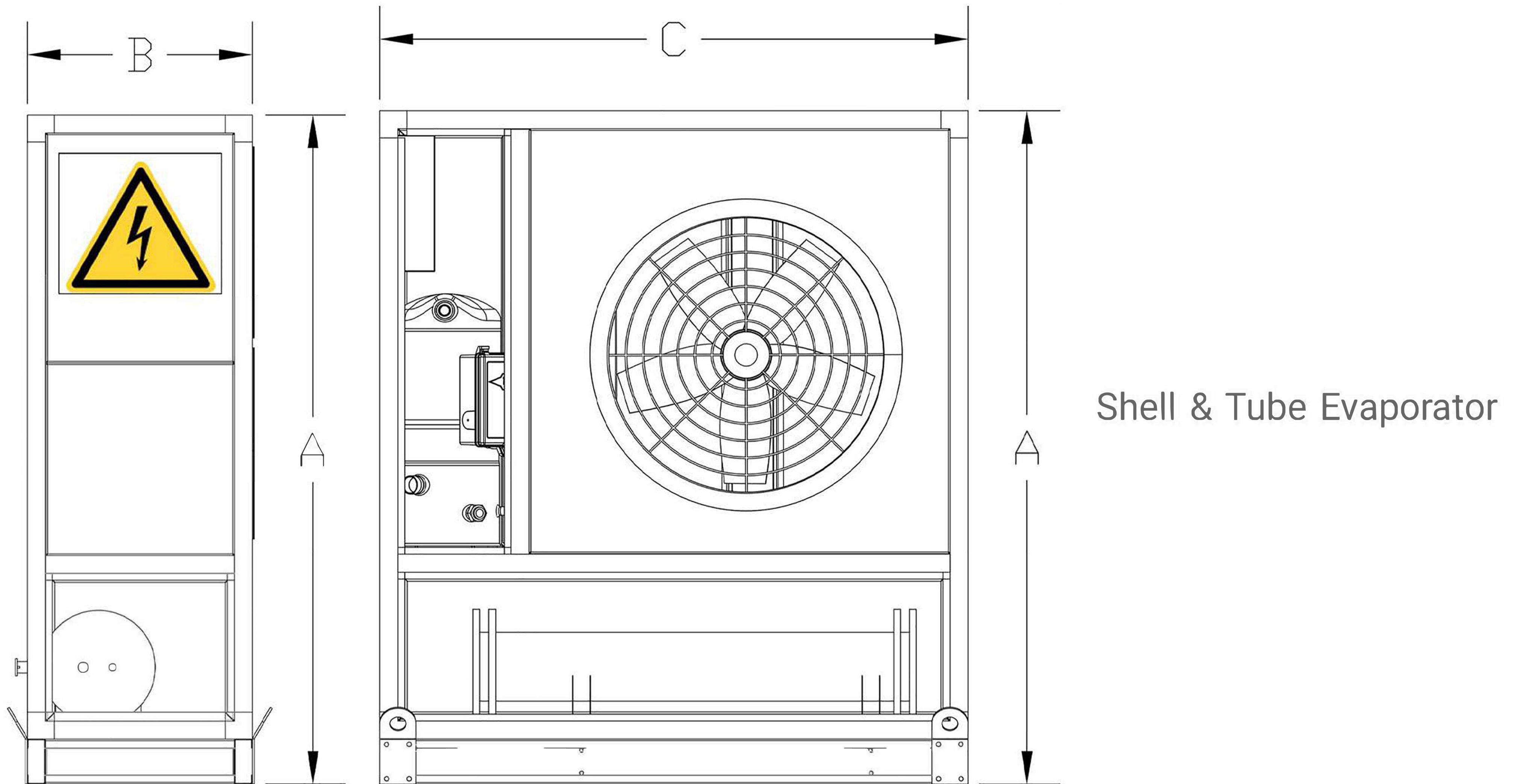

Dimensions	Plate	Height(A)	mm	1264	1439	1539	1539	1680
		width(B)	mm	500	500	500	600	600
		Length(C)	mm	1150	1200	1200	1400	1600
	Shell & Tube	Height(A)	mm	1490	1690	1690	1820	2155
		width(B)	mm	500	500	500	600	600
		Length(C)	mm	1300	1400	1400	1600	1600

Table 2